

# Bobcat E10

## Hydraulic Excavator



### WEIGHTS

<b>Operating weight with TOPS structure</b>	1138 kg
<b>Engine</b>	
<b>Make / model</b>	Kubota / D722-E2B-BCZ-6 (TIER 2)
<b>Fuel / Cooling</b>	Diesel / Liquid
<b>Maximum power at 2000 RPM (ISO 9249)</b>	7.4 kW
<b>Torque at 1600 RPM (SAE Net)</b>	39.1 Nm
<b>Number of cylinders</b>	3
<b>Displacement</b>	0.72 l
<b>Bore / Stroke</b>	67 mm / 68 mm
<b>Alternator</b>	12 V — 40 A
<b>Starter</b>	12 V — 1.4 kW
<b>Controls</b>	
<b>Steering</b>	Direction and speed controlled by two hand levers
<b>Hydraulics</b>	Two levers, control boom, bucket, dipperstick, upper structure slew

### HYDRAULIC SYSTEM

<b>Pump type</b>	Double gear pump
<b>Pump capacity</b>	2 x 10 l/min @ 2000 RPM
<b>Auxiliary flow</b>	20 l/min
<b>System relief pressure for implement circuits</b>	185 bar
<b>System relief pressure for auxiliary circuits</b>	185 bar
<b>Control valve</b>	Nine-spool parallel type, open centre

Call 01304 840845

**OVENDEN**

DIG IT > LOAD IT > CLEAR IT > MOVE IT

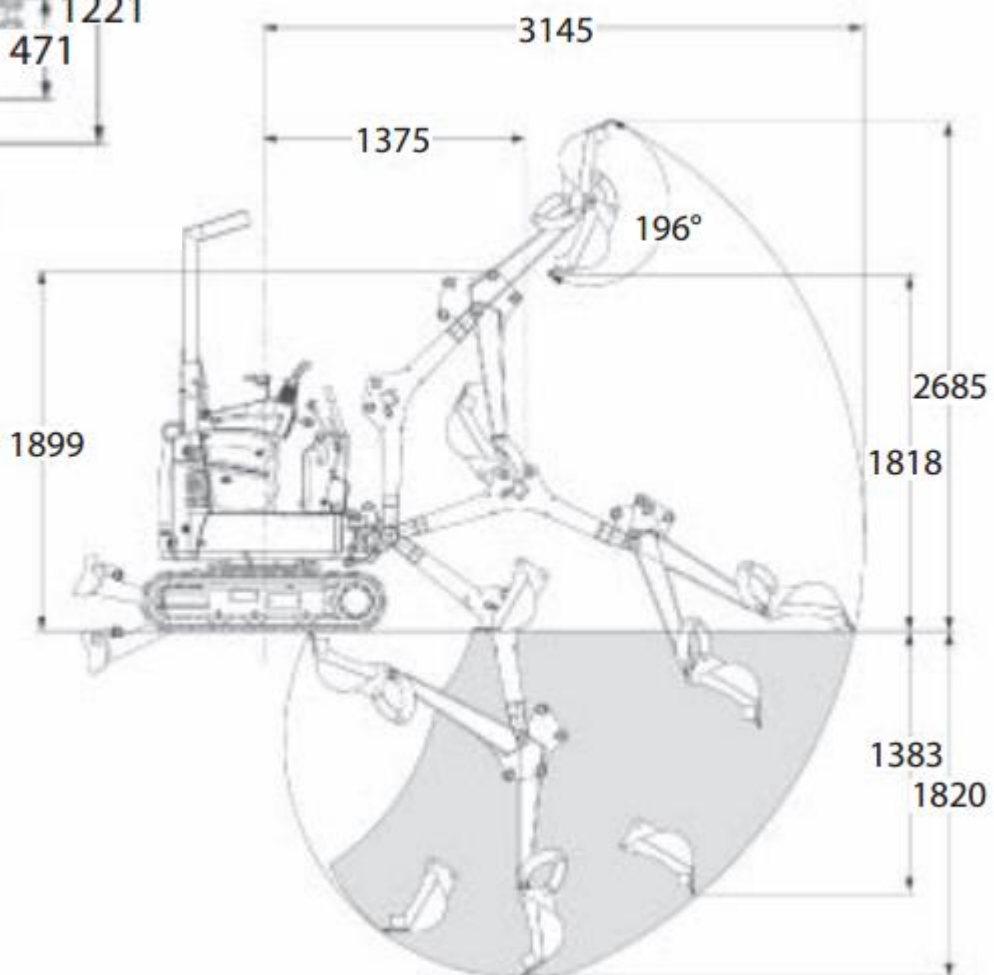
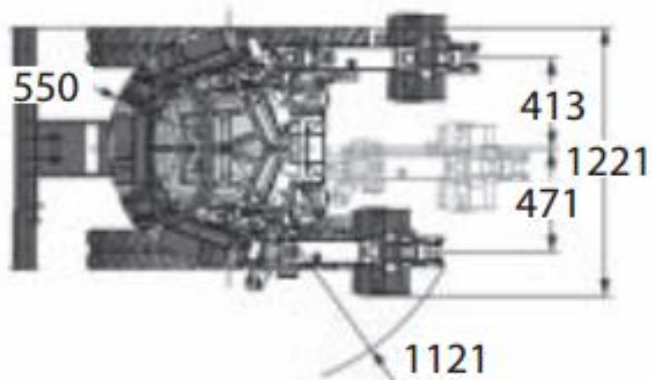
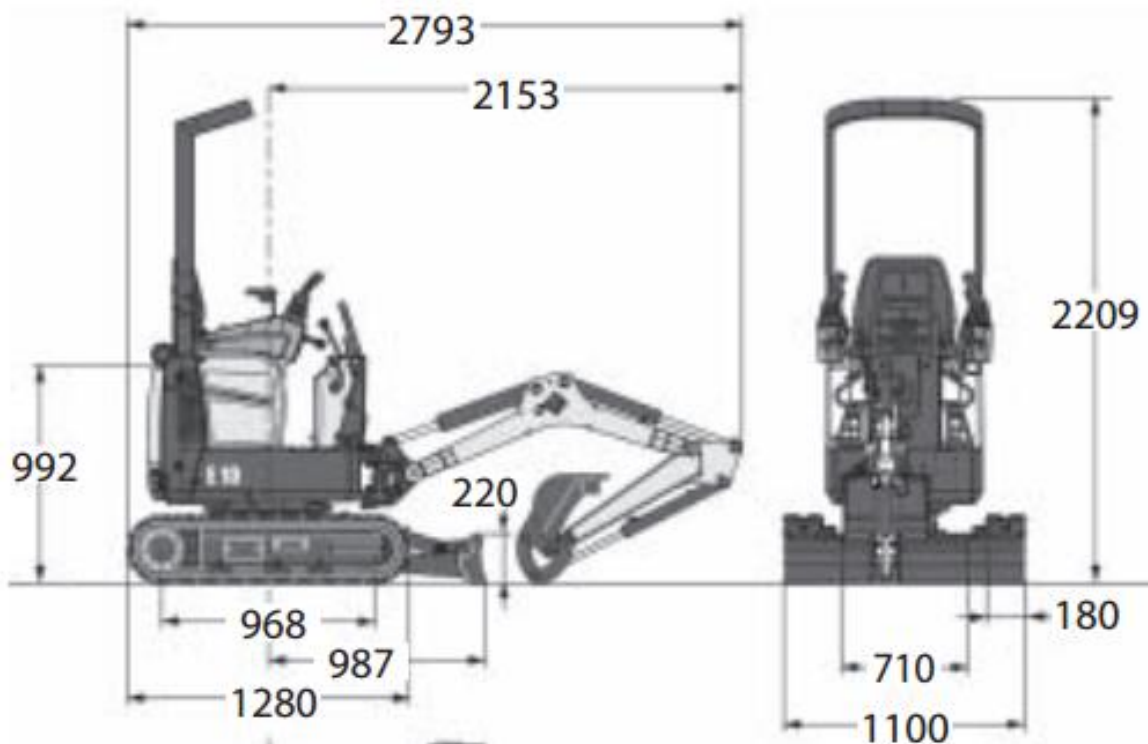

Call 01304 840845

**OVENDEN**

DIG IT > LOAD IT > CLEAR IT > MOVE IT